

Stretch Rack

Bicycle Storage & Parking Solutions

Assembly Instructions

Tools Required:

- Tape Measure
- 9/16" deep well socket
- 7/16" deep well socket
- Socket Wrench

Parts List:

	10bike	8bike	6bike
A. Tall Angle Iron (rear corner)	2	2	2
B. Short Angle Iron (front corner)	2	2	2
C. U-Channel, Back Horizontal	2	2	2
D. L-Channel, Front Horizontal	2	2	2
E. Horizontal Wheel Tray	10	8	6
F. Vertical Wheel Stabilizer	10	8	6
G. Cross brace (gold)	4	4	4
H. Lockbar (models 8100 series only)	10	8	6
I. Bolt 1/2"	40	36	32
J. Bolt 1.5"	20	16	12
K. Wheel stop pin	10	8	6
L. Washer	10	8	6
M. Kep nut 1/4"	60	52	44
N. Lock nut 3/8"	8	8	8

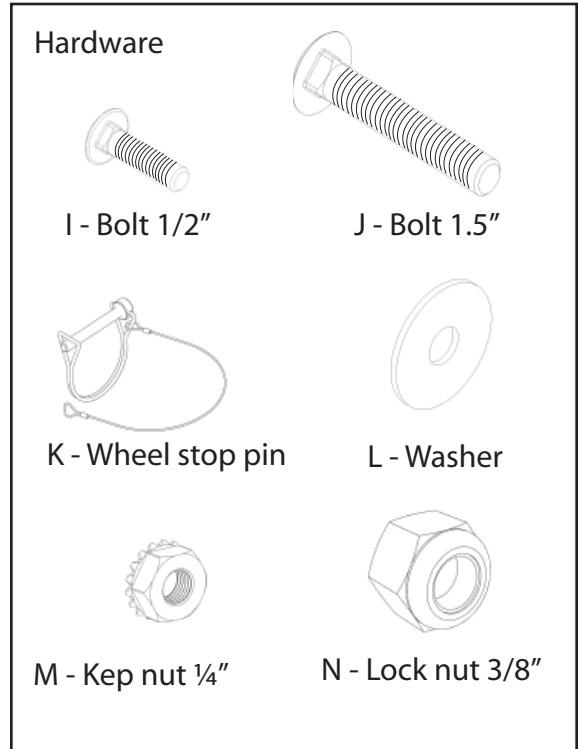

Figure 1

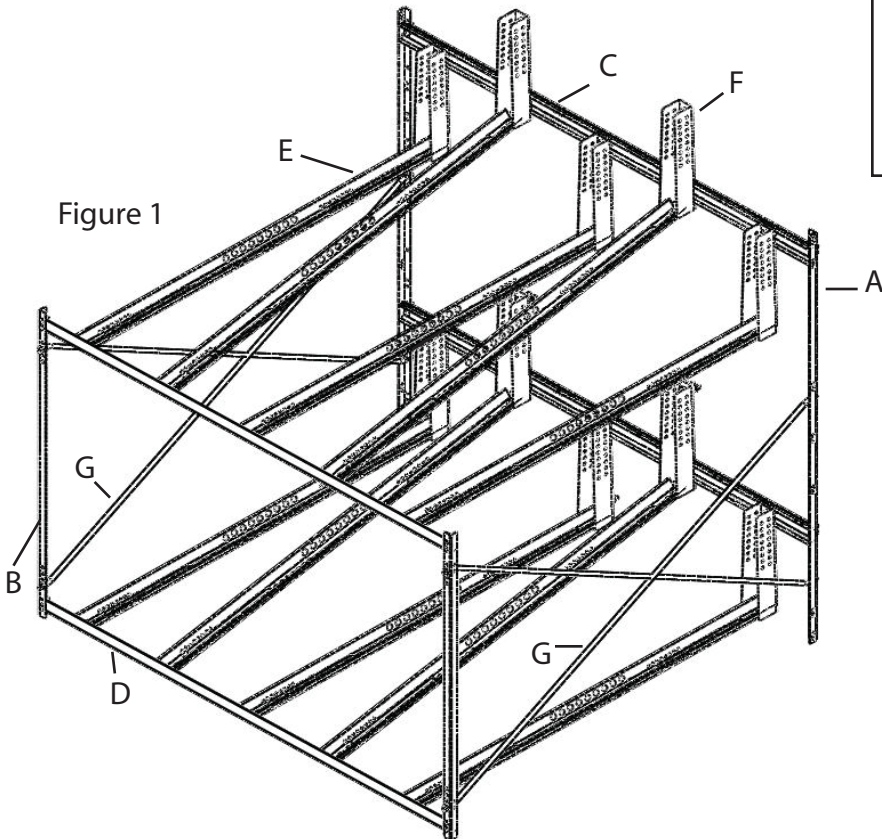
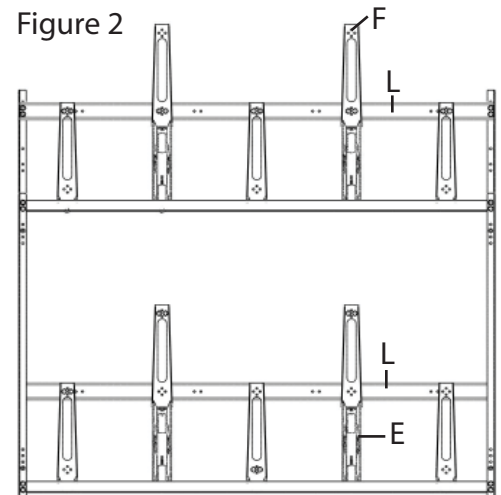

Figure 2



-Step 1: Rear Frame Assembly

Using rear vertical corner (part A) attach U-channels (part C) as seen in Figure 3 and 3a. Mount bottom U-channel 15 3/4" from floor. Mount top U-channel 60 3/4" from floor. Finger tighten with 1.5" carriage bolts (hardware I) and Kep nuts (hardware M).

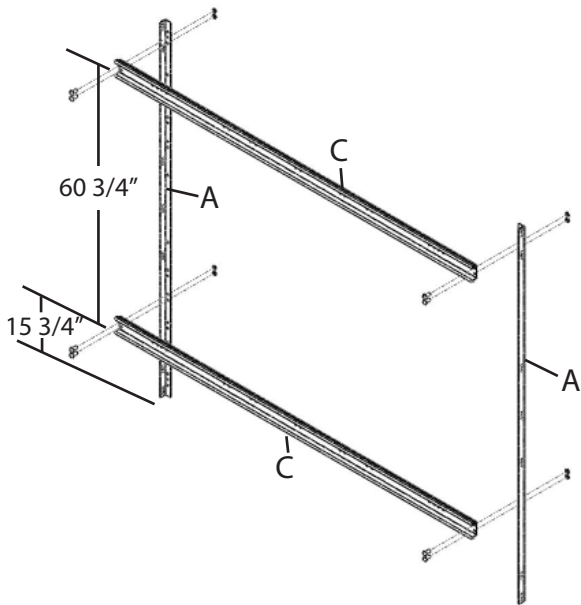

Figure 3

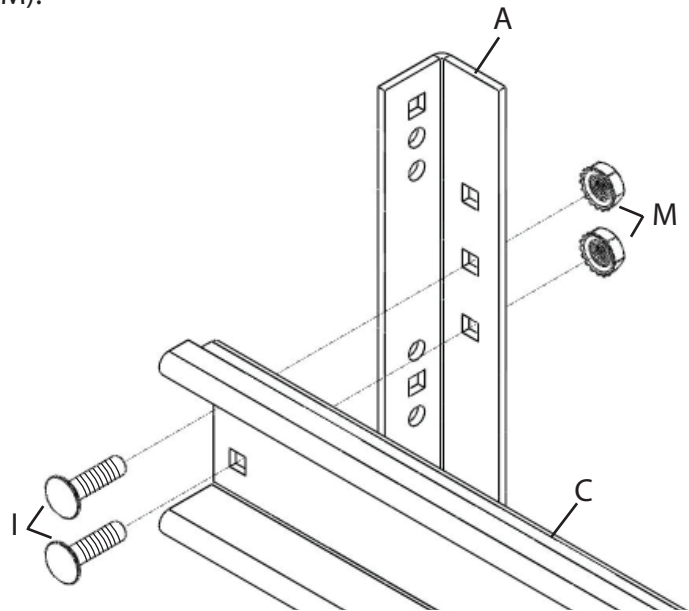

Figure 3a

-Step 2: Front Frame Assembly

Using front vertical corner (part B) attach L-channel (part D) as seen in Figure 4 and 4a. Mount bottom L-channel 1 1/8" from floor. Mount Top L-channel 46 1/8" from floor. Finger tighten with 1.5" carriage bolts (hardware I) and Kep nuts (hardware M).

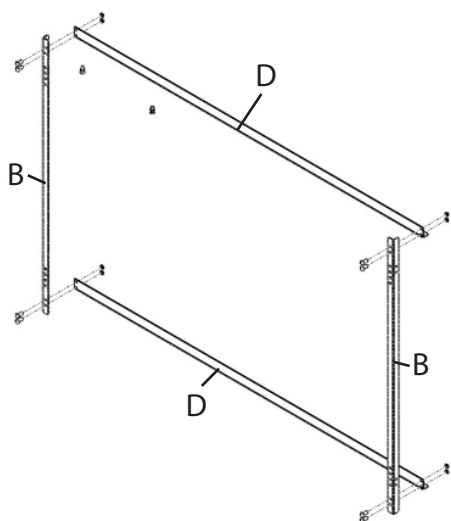

Figure 4

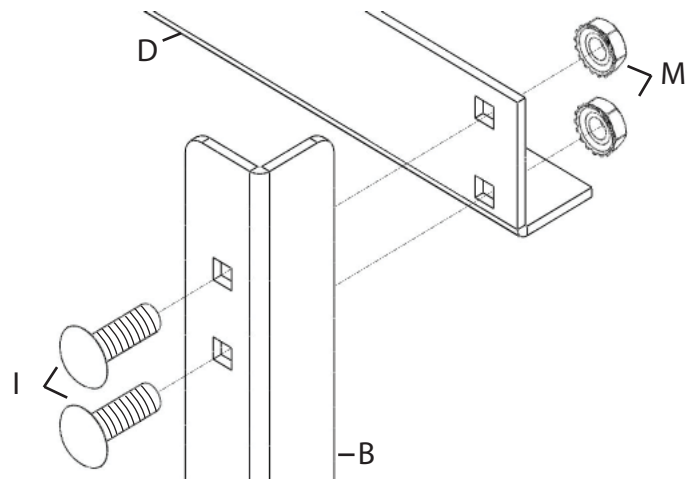

Figure 4a

-Step 3: Attaching front and rear frames

First attach two cross rods (part G) to front vertical corner at 5" and 42" from floor using 3/8" Locknut (hardware N). Next, attach the other end of the cross rods to rear vertical corner (part A) at 9 1/2" and 38 1/2" from the floor as seen in Figure 5. Repeat assembly for second side. Location of cross rods on front vertical corners are adjustable to set rack parallel to wall.

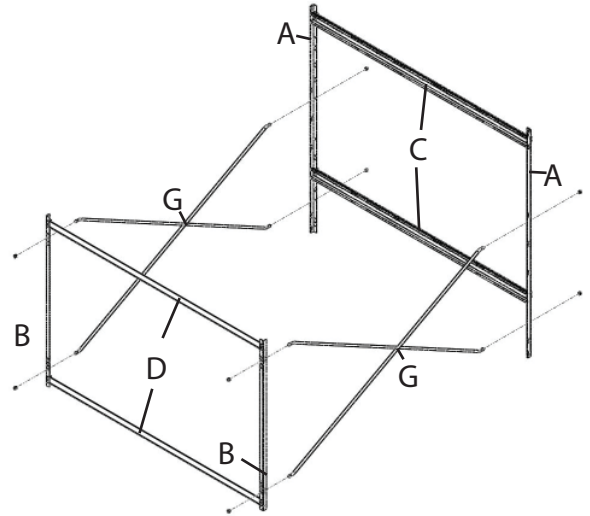

Figure 5

-Step 4: Planning Bike tray layout

Alternate wheel trays from raised position to flat position to space handlebars and minimize interference with adjacent bikes.

Bike Tray Requirements:

	10 bike 8010,8110	8bike 8080*,8180*	8 bike 8018,8118	6bike* 8016*,8116*
Flat trays needed	6	4	4	4
Raised trays needed	4	4	4	2
Bike spacing	14.4"	18"	13.5"	18"

*These models can be upgraded to hold an additional 2 bikes per rack by reducing bike spacing. Model

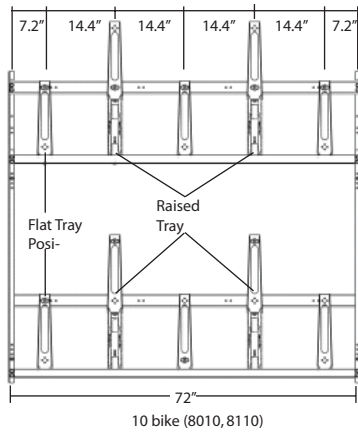

10 bike (8010,8110)

Figure 6

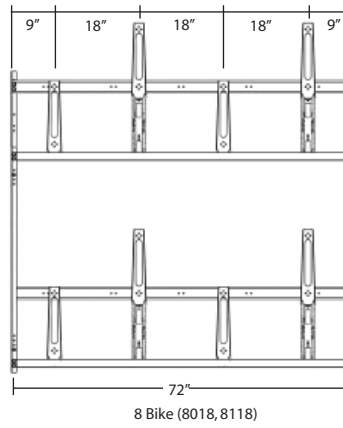

8 Bike (8018,8118)

Figure 6a

Note: For multiple units, assembly should be modified to continue staggered positions. Four additional bolt I and Nut M are included to connect parts A and B for adjacent setups.

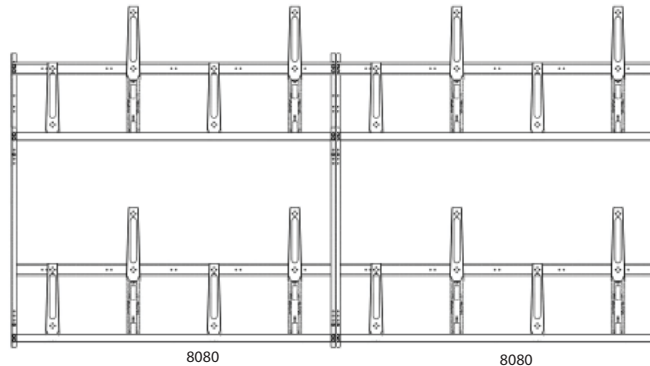

Figure 7

-Step 5: Bike Tray Assembly

Flat tray assembly:

Attach Horizontal Wheel Tray (Part E) to Vertical Wheel Stabilizer (Part F) using the second square hole from the end. Use a 1.5" carriage bolt, washer and kep nut, finger tight.

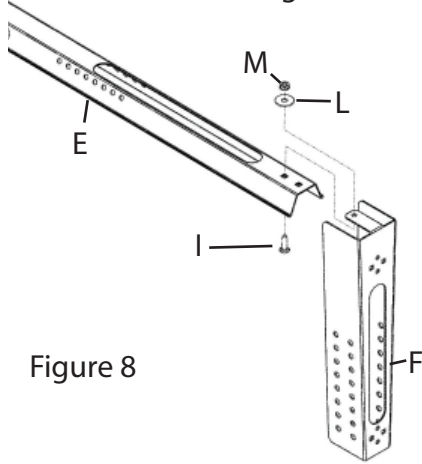

Figure 8

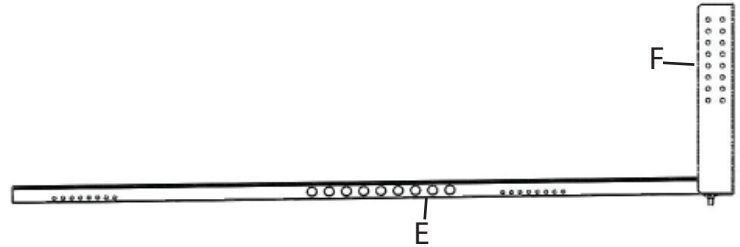

Figure 8a

Raised tray assembly:

Attach Horizontal Wheel Tray (Part E) to Vertical Wheel Stabilizer (Part F) using the first square hole from the end. Use a 1.5" carriage bolt, washer, and kep nut, finger tight.

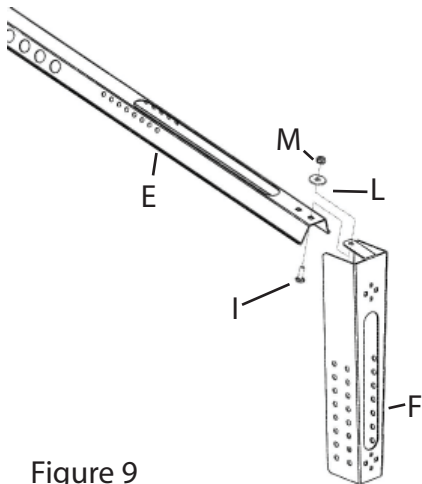

Figure 9

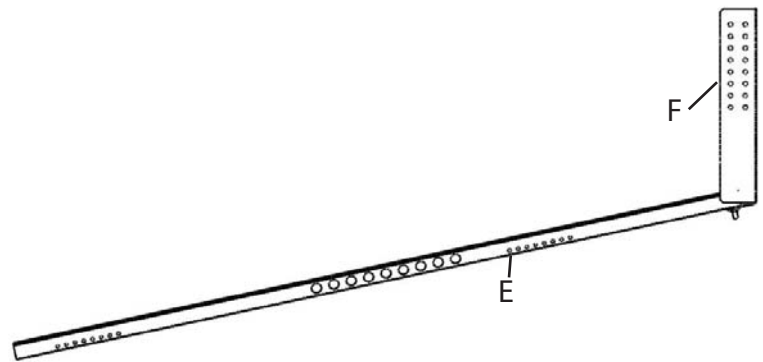
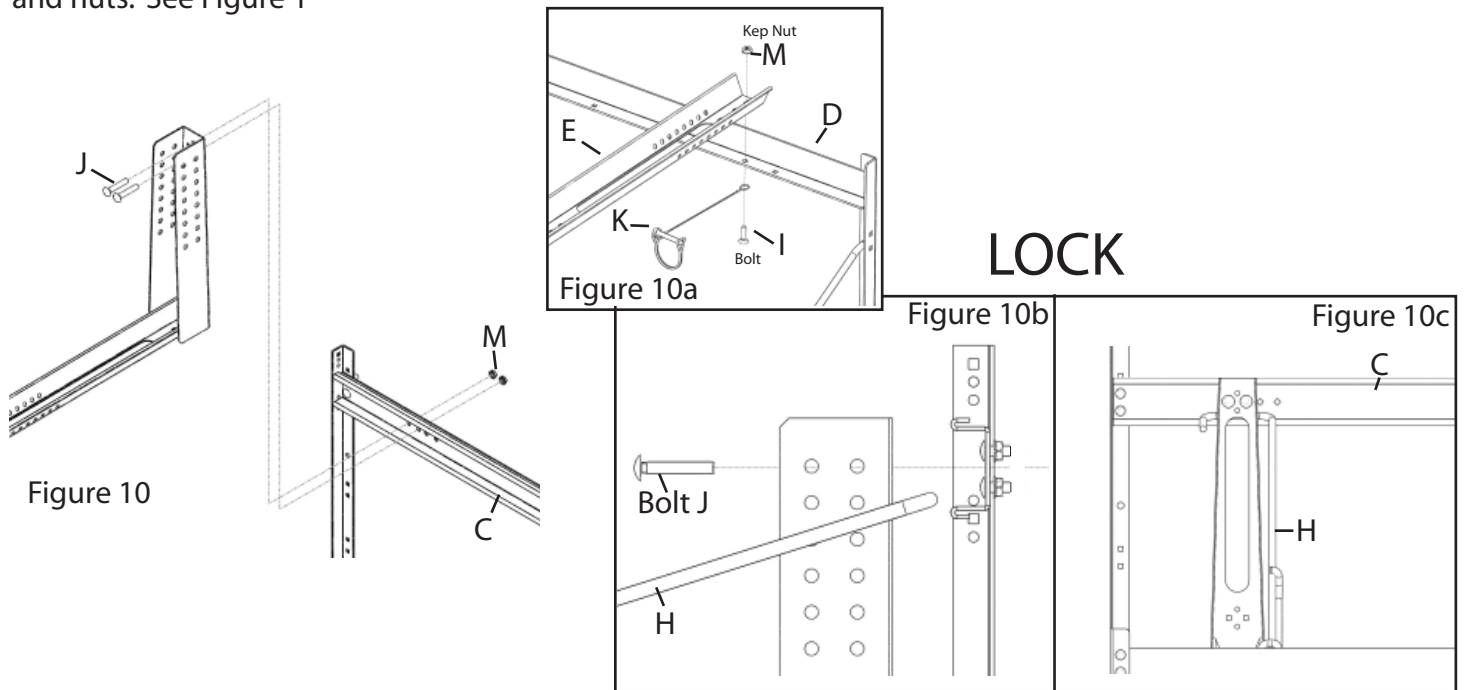

Figure 9a

-Step 6: Mounting bike trays to frame

Flat tray attachment:

Using a flat tray assembly from step 5, attach to front L-channel (part D) through round hole located second from the end on the bike tray. Mount lanyard of the wheel stop pin (part K) between L-channel and horizontal wheel tray. Attach vertical tray through top mounting holes to rear U-channel (part C) using 1.5" bolts and nuts. See Figure 1



Raised tray attachment:

Using a raised tray assembly from step 5, attach to front L-channel (part D) through round hole located closest to the end on the bike tray. Mount lanyard of the wheel stop pin (part K) between L-channel and horizontal wheel tray. Attach vertical tray through bottom mounting holes to rear U-channel (part C) using 1.5" bolts and nuts. See figure 11 and 11a for spacing.

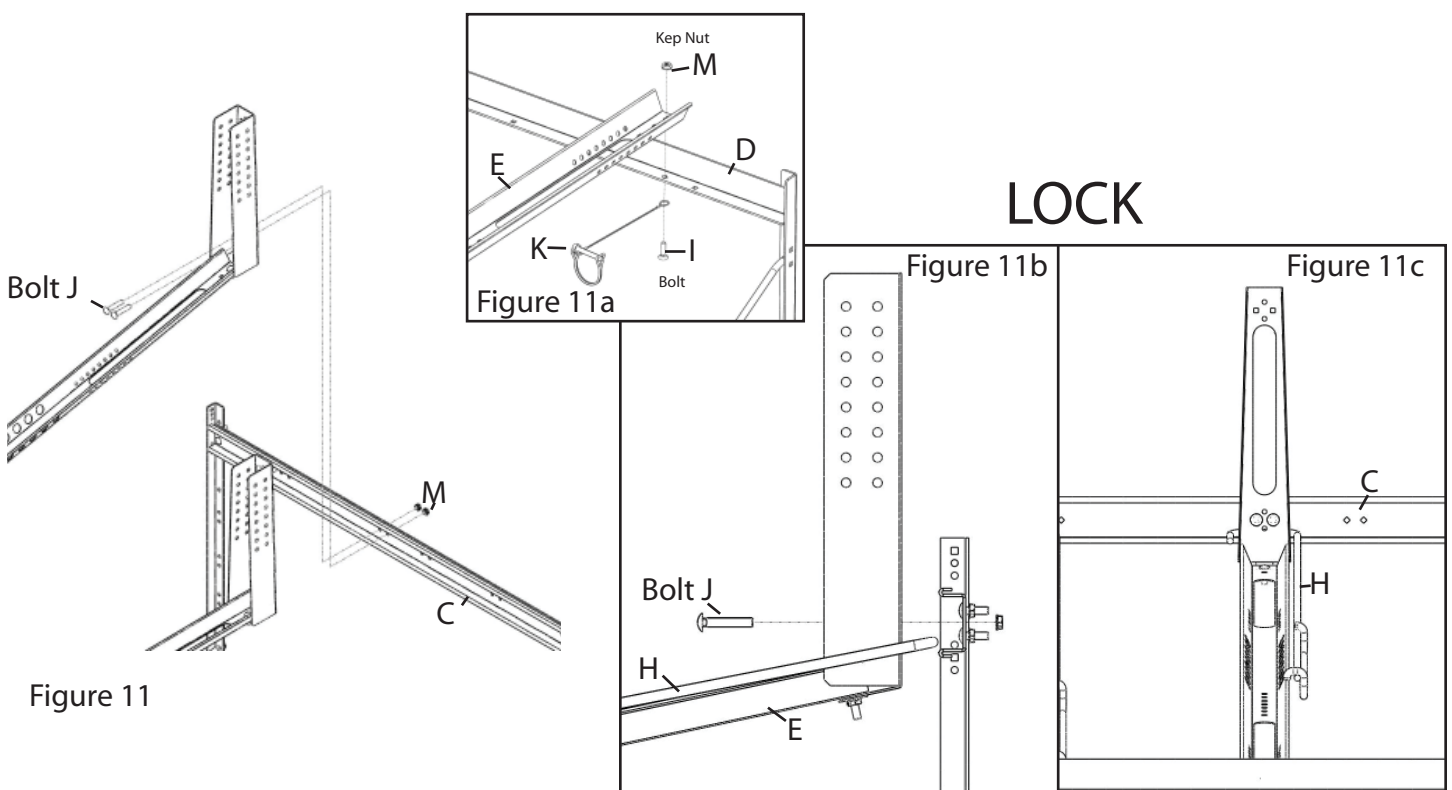

-Step 7: Final check

- Double check location and assembly of all parts, reference Figure 1. Then tighten down all nuts snugly with ratchet. Move rack into final location.
- Adjust cross braces as needed to ensure the rack is square and parallel to the back wall.

User Tips:

1. Always load bikes handlebar first. This will elevate the front wheel of every other bike, staggering the handlebars. Wider handlebars will work best when loaded on the elevated bike positions
2. Lock bikes with a user-provided lock for any model as shown in figure 12.



3. For maximum stability, it is important for the bike to be positioned all the way forward in the vertical wheel tray. Some bikes will require wheel stop pin to be placed through the horizontal wheel tray to keep the bike in this position. The need and location of the wheel stop pin will vary depending on wheel size as well as bike size.

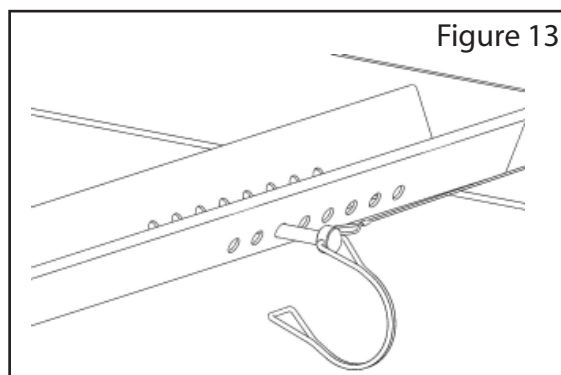

WARNING

Manufacturer and seller expressly disclaim any and all liability for personal injury, property damage or loss, whether direct, indirect or incidental, resulting from the incorrect attachment, improper use, inadequate maintenance, or neglect of this product.

WARRANTY

We warrant this product to the first consumer to be free from defect in material and workmanship for a period of one year from date of purchase. (Please retain your sales slip for your records.) Any product or part thereof found to be defective within that period will be replaced without charge provided that: (1) the product was not misused; (2) no alterations or modifications were made; (3) its failure resulted from a defect in material or workmanship and not from normal wear expected in the use of the product; (4) the product or part is delivered, freight prepaid, to Saris Cycling Group. Manufacturer's only obligation shall be to replace such products or parts proved to be defective. Damage to mounting surface is not covered under warranty.

Made in U.S.A.
16861 8/06

Saris Cycling Group
5253 Verona Road
Madison WI 53711
1-800-783-7257
www.saris.com