

YAKIMA AXE/SHOVEL BRACKET FOR WARRIOR BASKETS



CARRIES A SHOVEL OR SINGLE BLADED AXE AND MOUNTS OUTSIDE YAKIMA'S LOADWARRIOR OR MEGAWARRIOR.

RECOMMENDED TOOLS:

- Flat screwdriver
- 7/16" wrench

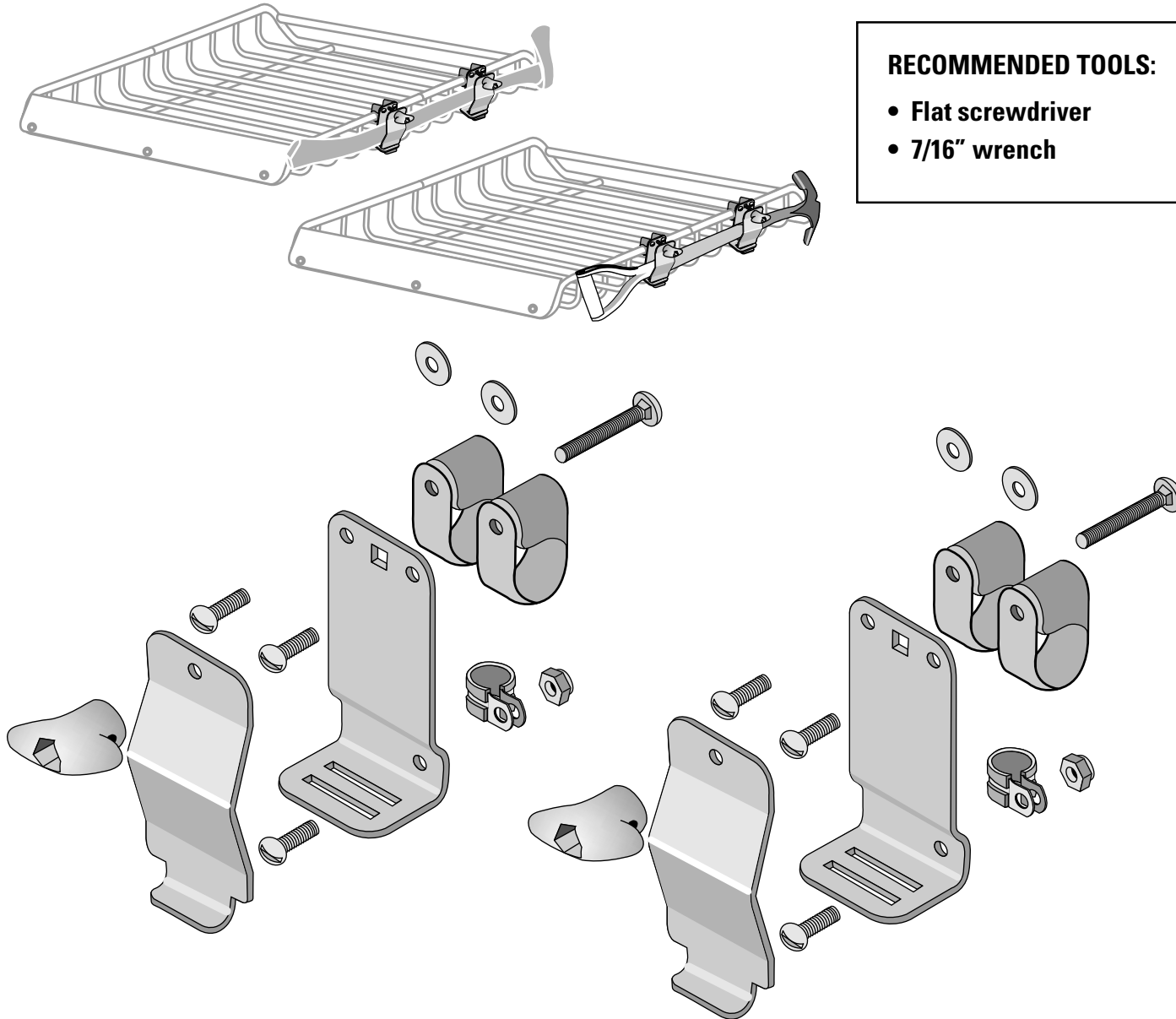

IMPORTANT WARNING!
IT IS CRITICAL THAT ALL YAKIMA RACKS AND ACCESSORIES BE PROPERLY AND SECURELY ATTACHED TO YOUR VEHICLE. IMPROPER ATTACHMENT COULD RESULT IN AN AUTOMOBILE ACCIDENT, AND COULD CAUSE SERIOUS BODILY INJURY OR DEATH TO YOU OR TO OTHERS. YOU ARE RESPONSIBLE FOR SECURING THE RACKS AND ACCESSORIES TO YOUR CAR, CHECKING THE ATTACHMENTS PRIOR TO USE, AND PERIODICALLY INSPECTING THE PRODUCTS FOR ADJUSTMENT, WEAR, AND DAMAGE. THEREFORE, YOU MUST READ AND UNDERSTAND ALL OF THE INSTRUCTIONS AND CAUTIONS SUPPLIED WITH YOUR YAKIMA PRODUCT PRIOR TO INSTALLATION OR USE. IF YOU DO NOT UNDERSTAND ALL OF THE INSTRUCTIONS AND CAUTIONS, OR IF YOU HAVE NO MECHANICAL EXPERIENCE AND ARE NOT THOROUGHLY FAMILIAR WITH THE INSTALLATION PROCEDURES, YOU SHOULD HAVE THE PRODUCT INSTALLED BY A PROFESSIONAL INSTALLER SUCH AS A QUALIFIED GARAGE OR AUTO BODY SHOP.

Part #1033041 RevA

BEFORE YOU BEGIN

Tools must be installed head to the rear.

- Axe mounts blade up.
- Shovel must clear crossbar and curve away from you.

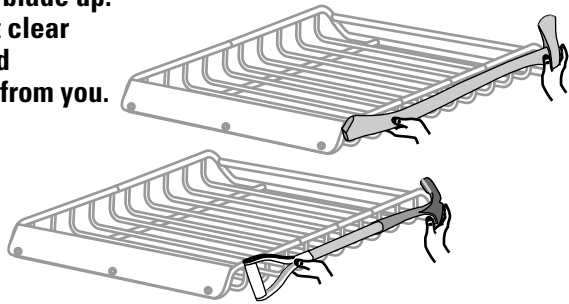

- Determine the best spacing for brackets.

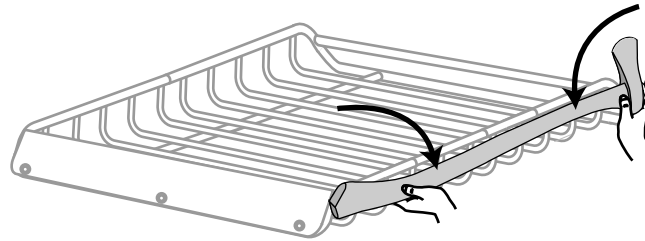

NOTE: Install brackets a minimum of 3 spaces apart and not over a joint.

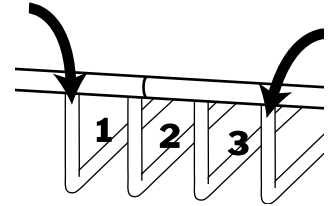

- 1** Snap 2 larger clamps around the upper tube on either side of the 1/2" vertical tube.

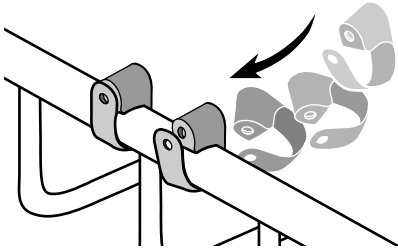

- 2** Attach back plate.
- Insert spacers.
 - Insert screws.
 - Do not tighten completely.

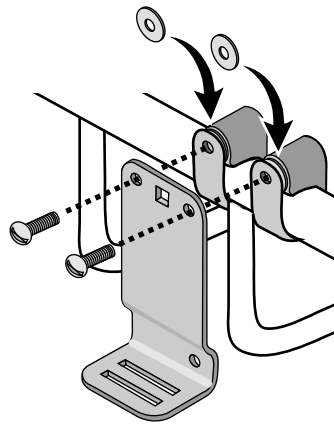

- 3** Pry apart smaller clip and attach at base of vertical tube flat side to front.

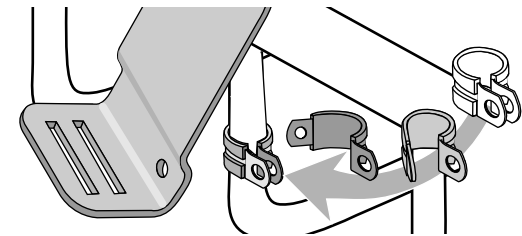

- 4** Insert and tighten screw using wrench to stabilize locknut.

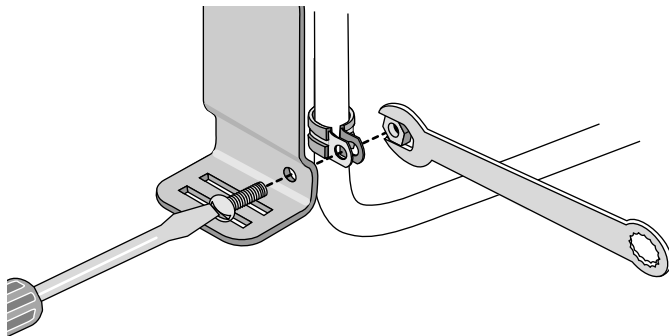

- 5** Tighten all screws.

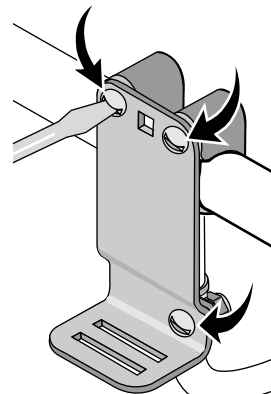

- 6** Install front plate into front slot.

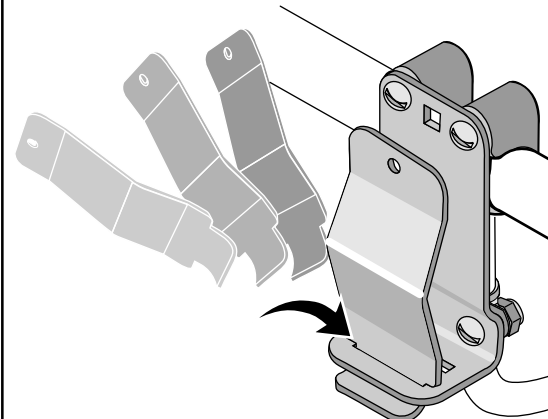

- 7** Repeat installation for second bracket.

INSTALL BRACKETS A MINIMUM OF 3 SPACES APART AND NOT OVER A JOINT.

- 8** Place shovel or axe into brackets.
Axe head mounts to the rear, blade up.

Shovel must clear crossbar and curve away from you.

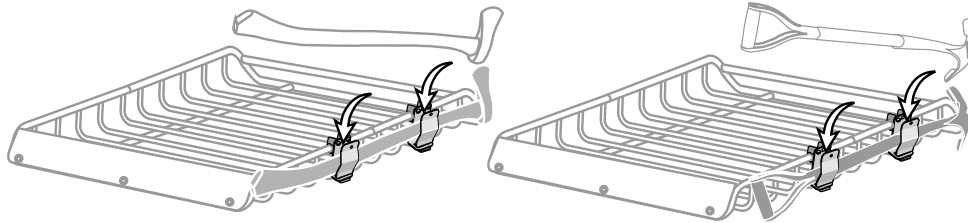

Note: Shovel or axe must not exceed 8 pounds.

- 9** Insert long screw from back and secure with black knob.

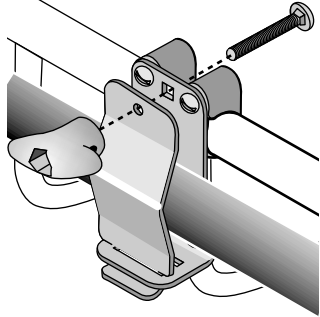

- 10** If there is not enough tension to hold the handle securely with knob fully tightened, reinsert the front plate into the back slot.

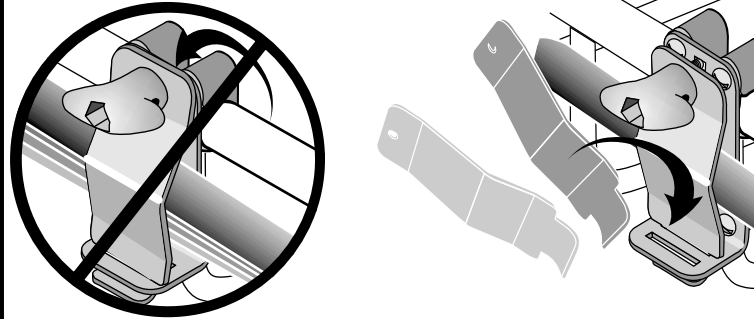

READ THESE WARNINGS!



WHEN NOT IN USE, TIGHTEN KNOB COMPLETELY.

ATTACHMENT HARDWARE CAN LOOSEN OVER TIME. CHECK AND TIGHTEN IF NECESSARY, BEFORE EACH USE.



Be sure all hardware is secured according to instructions. Failure to perform safety checks before driving away can result in property damage, personal injury, or death.



Do not use for anything but shovels and single bladed axes.

NOT RECOMMENDED FOR CARRYING THROUGH AUTOMATIC CAR WASHES

KEEP THESE INSTRUCTIONS!

IF YOU NEED FURTHER TECHNICAL ASSISTANCE OR REPLACEMENT PARTS:
Please contact your dealer or call us at (888) 925-4621 or (707) 826-8000, Monday through Friday, 8:00am to 5:00pm Pacific time.

LIMITED WARRANTY

Yakima Products ("Yakima") will repair or replace merchandise which proves defective in materials and/or workmanship. The limited warranty is effective for three years from the date of purchase. The limited warranty is applicable only if the Fit List and instructions are followed and the products are used properly. If a customer believes that a Yakima product is defective, the customer must return it to an authorized Yakima dealer with proof of purchase. Yakima will then issue authorization to the dealer for the return of these products. If an article is found to be defective upon inspection by Yakima, Yakima will repair or replace the defective article at its discretion without charge. The customer will pay freight to Yakima, and Yakima will pay any applicable return freight. Unauthorized returns will not be accepted. Normal wear and tear of Yakima products or damage resulting from misuse, accidents, or alterations are not covered by this Limited Warranty. The purchaser acknowledges that Yakima has no control over the attachment of its products to vehicles or the attachment of items to the Yakima products. Accordingly, Yakima cannot assume responsibility for any damage to any property arising out of the improper attachment or use of its products. In addition, this Limited Warranty applies only to Yakima products and not to other products used in conjunction with Yakima products. This Limited Warranty is in lieu of all other warranties, expressed or implied, and does not cover consequential damages of any kind that may arise from the use or misuse of any Yakima product.