

# THULE<sup>®</sup> SWEDEN 699 ROUND TRIP™ BIKE TRAVEL CASE

## PARTS INCLUDED

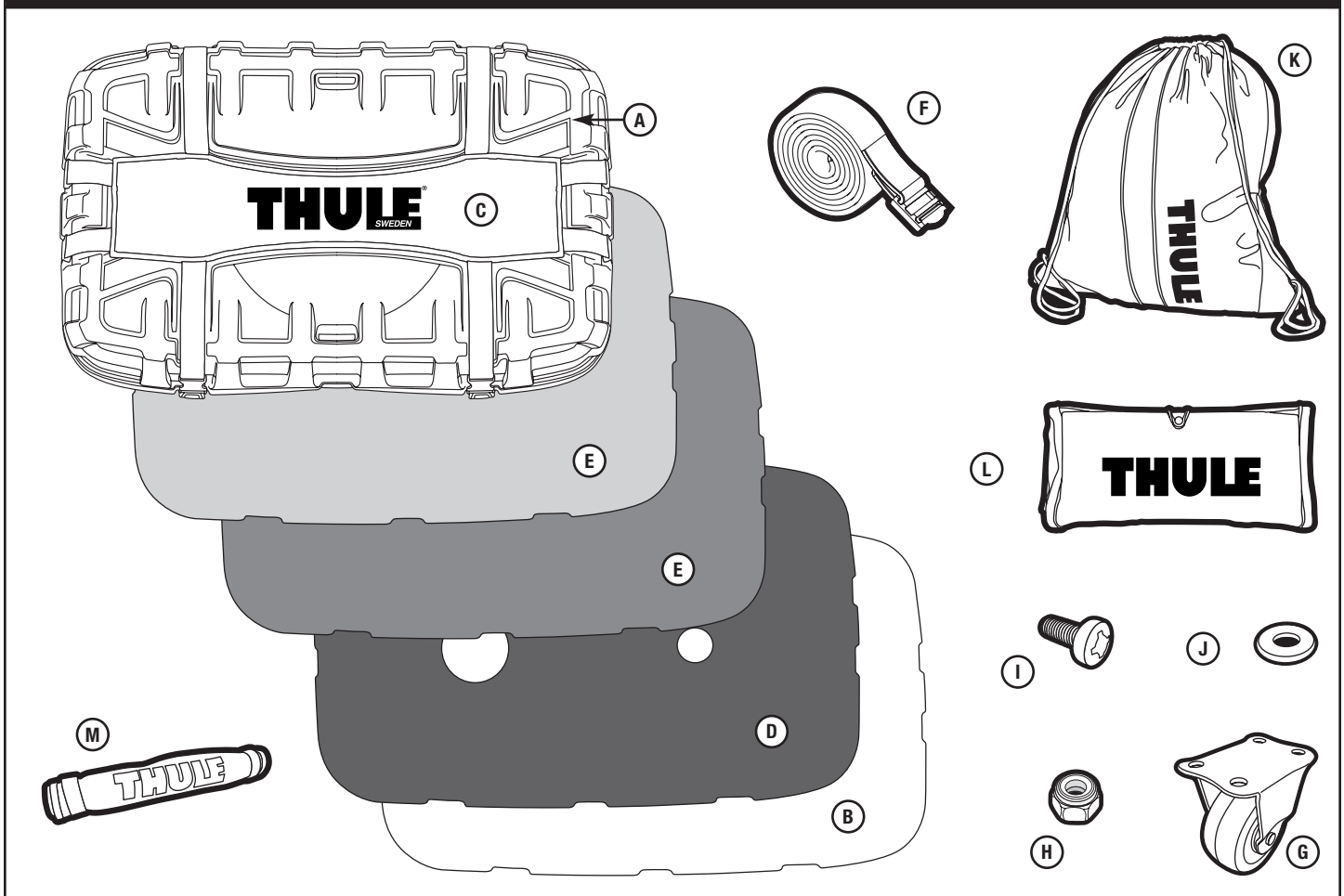

part	description	part number	qty.
A	top shell	05325	1
B	bottom shell	05327	1
C	strap harness	05310	1
D	plastic shield	05328	1
E	protective foam	05329	2
F	tie-down strap	10169	2
<b>PARTS BAG</b>		<b>05360</b>	<b>1</b>
G	caster	05331	2
H	lock nut	05338	8
I	screw	05340	8
J	washer	05339	8
<b>PARTS BAG</b>		<b>05314</b>	<b>1</b>
K	tote bag	05311	1
L	tool bag	05312	1
M	chain/tube wrap	05313	2

## WARNINGS/LIMITATIONS

- The Round Trip is designed to accommodate bicycles of a variety of sizes and frame designs, which may require extra protection in areas susceptible to scratches and dents.
- Wheels should be carefully packed to avoid damage to spokes.

## ACCESSORIES

### TRANSPORTING THE ROUND TRIP™ – [RFM] ROOF MOUNT KIT (SOLD SEPARATELY)

Also available from Thule is the RFM Roof Mount Kit for transporting the Round Trip on top of your car. The RFM consists of heavy-duty nylon straps and weather stripping for protection from the elements and is suitable for Thule standard and Xsporter load bars, Yakima®, and most factory installed racks.

### PARTS INCLUDED (RFM SOLD SEPARATELY)

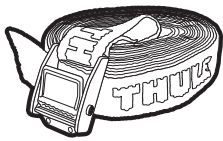

A



B

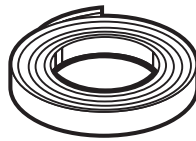

C

part	description	part number	qty.
A	strap	753-2030-07	2
B	buckle bumper	853-5593	2
C	foam gasket	01315	1

## ASSEMBLY

### 1A

#### PREPARING YOUR ROUND TRIP BIKE TRAVEL CASE:

- The Round Trip will arrive in a clamshell position. Remove the top half, foam pads and plastic shield - set aside.
- Unpack your Thule tote bag, tool bag, chain and tube wraps as you will use these during the packing process.
  - \* **TOTE BAG:** Great for clothes, helmet, shoes or any thing you want to keep away from the grime and grease of your bicycle.
  - \* **TOOL BAG:** Don't leave small items behind! Carry wrenches, bike skewers, even pedals in your tool bag and pack it along with everything else.
  - \* **CHAIN WRAP:** Secure the bike chain away from your frame.
  - \* **TUBE WRAP:** Use this to protect any other areas that may be vulnerable to metal on metal contact. Reinforce with foam padding or bubble wrap.
  - \* **FOR EXTRA PROTECTION:** Using extra padding wherever possible - foam or bubble wrap secure with zip ties or string works great and is readily available at your local shipping supply or hardware store.

### 1B

- Assemble wheels to bottom shell as shown.

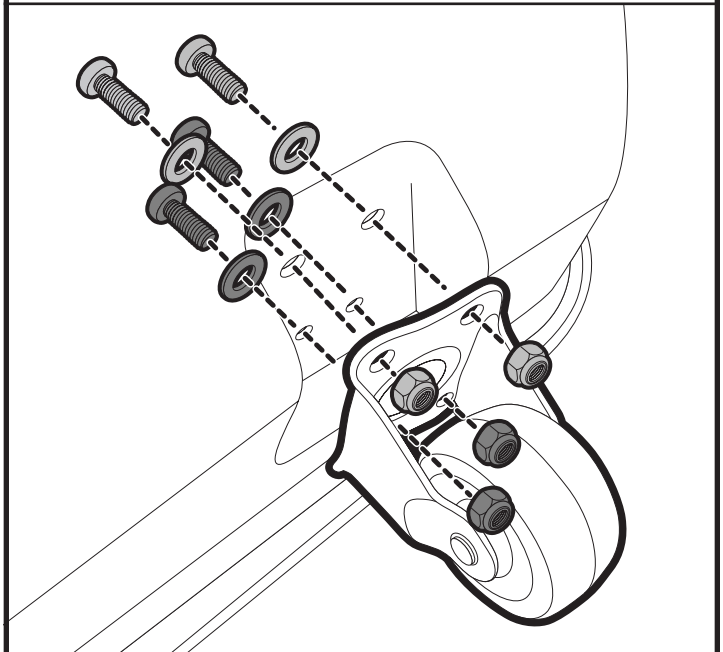

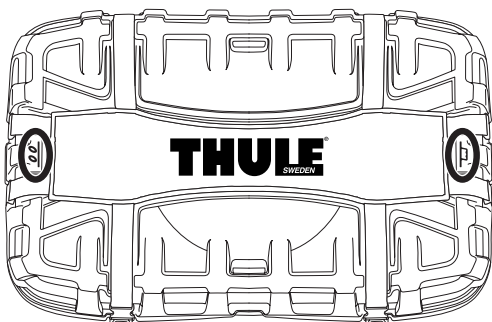
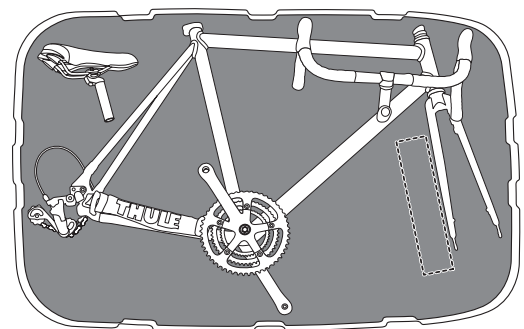
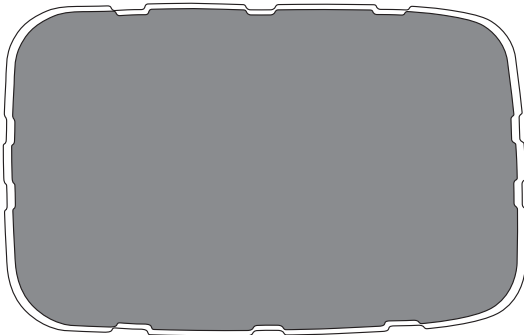
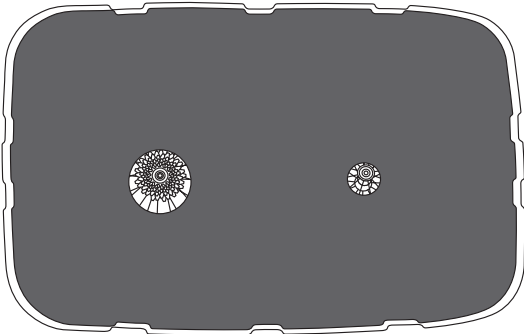
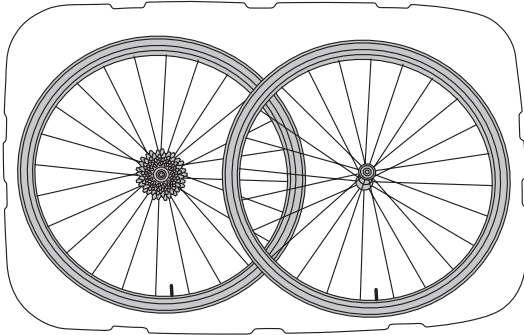

**a PREPARING YOUR BIKE:**

- Position your bike for disassembly. Place items in your tote bag and tool bag to ensure nothing is left behind.

- Remove front and rear wheels. Remove skewers.

**HINT:** Pack these in your Thule tool bag.

- Unthread pedals.

**HINT:** Place these in your Thule tote or tool bag.

- Remove seat/seat post. **DON'T FORGET** to loosely tighten the binder bolt after the seat post has been removed.

**HINT:** Mark the position of your seat with tape for easy reassembly.

- b** Lay rear wheel into the rear of bottom shell cog side up followed by the front wheel. Place plastic shield over the wheels so that it rests on the shelf around the perimeter of the bottom shell. The larger hole should be positioned over the cog set. Place one layer of foam over plastic shield.

- c** Disassemble handlebars. Depending on your frame style you may need to either loosen handlebars and position along the top tube or remove handlebars completely and position along the fork.

**HINT:** Reinforce this area against metal-on-metal contact!

- d** Line up the right crank arm (chain side) with the chain stay tube. Capture the slack in the chain with the Chain Wrap then secure to chain stay tube. The Chain Wrap will prevent chain oil and dirt from contacting bike case contents.

**HINT:** To prevent damage in while in transit, you may wish to secure the derailleur tension pulley to the chain stay using your own zip

- e** Secure the bike frame into a center position by threading the tie-down straps, which we have provided, through the frame and metal rings attached to the inside of the bike case.

- f** Place seat/post either inside frame triangle or behind seat stay.

**HINT:** This area may require additional security against metal-on-metal contact by using your own foam padding or bubble

- g** Lay second foam sheet over frame. Make sure no bicycle parts are touching sides of case.

- h** Place the Tool Bag and Tote Bag in this layer to ensure they will be held in position by protective foam.

- i** Place top shell over bottom shell of case.

**HINT:** Handle and Wheel icons at the top and bottom of the top shell indicate proper alignment.

- j** Loosen all straps. Latch buckles then pull tabs to cinch straps snugly.

- k** For extra security, rings on both sides of case will accept most padlocks.

**1****SECURING FOR TRANSPORT**

- Affix the foam gasket to inside flange in top shell.

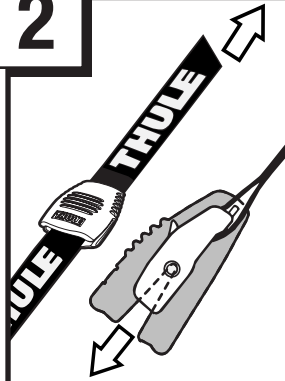
**2**

- Route free end of strap, with logo side up, through the Buckle Bumper as shown. Pull Buckle Bumper over buckle to protect and vehicle while strapping down bike case.

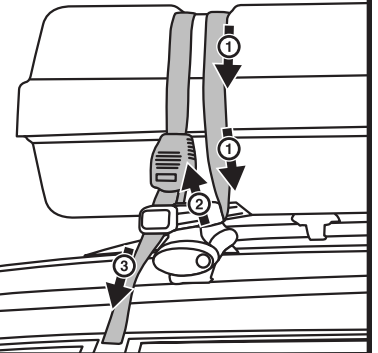
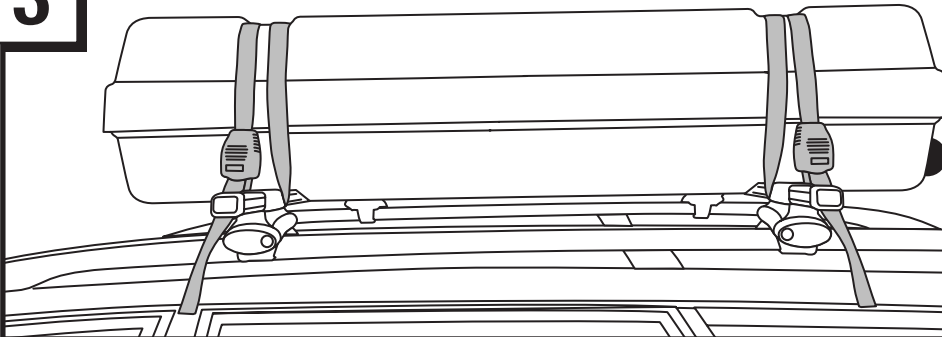
**3**

- Route free end of strap, with logo side up, through the Buckle Bumper as shown. Pull Buckle Bumper over buckle to protect and vehicle while strapping down bike case.

**THULE RACK GUIDELINES**

When using Thule Car Racks and accessories, the user must understand the precautions. The points listed below will assist you in using the rack system and will encourage safety. Please review the instructions and warranty carefully. Assembly and installation are the end user's responsibility and beyond Thule's control. Therefore, Thule exclusively limits its warranty to the repair or replacement of a defective Thule product for up to five years from retail purchase. Damage to your vehicle, cargo, or to any person or property is excluded.

- Check the Thule Fit Guide or the manufactures' guidelines for any restrictions about using hitch-mounted boxes.
- Check local and state laws governing projection of objects beyond your vehicle. Be aware of the width and height of your cargo since clearance of speed bumps and other low-lying objects can affect the load. All cargo will affect the vehicle's driving behavior. Never drive with any lock, knob, or rack in the open or unlocked position.
- Make sure all knobs, bolts, screws, straps, and locks are firmly attached, tightened and locked before every trip. Knobs, bolts, screws, straps, and locks must be periodically inspected for signs of wear, corrosion, and fatigue. Check your load at stops during the trip to insure continued fastening security.
- Remove your Thule rack and accessories when they are not in use and before entering automatic car washes.
- For safety to your vehicle and rack system, obey all posted speed limits and traffic cautions. Adapt your speed to the conditions of the road and the load being carried.
- Do not use Thule Car Racks and accessories for purposes other than those for which they were designed. Do not exceed their carrying capacity. Failure to follow these guidelines or the product's instructions will void the warranty.
- Consult with your Thule dealer if you have any questions regarding the operations and limits of Thule products. Review all instructions and warranty information carefully.
- All locks must be turned and moved periodically to ensure smooth operation. Use graphite or similar dry lubricant to help this. The locks are designed to deter vandalism and theft. Remove valuable gear if your vehicle is unattended for an extended period. Place at least one key in the glove compartment. Replacement keys are available through your dealer or Thule direct at [www.thuleracks.com](http://www.thuleracks.com).
- Not intended for off-road use.
- Do not install on a trailer or other towed vehicle.

**THULE**<sup>®</sup>  
SWEDEN

Made in U.S.A. • THULE INC., 42 SILVERMINE RD. • SEYMOUR, CT 06483 • [www.thule.com](http://www.thule.com)

05333